

AVERY DENNISON MARKETING SPECIFICATION

HISTORY

THE SUBJECT MATTER DISCLOSED HEREIN EMBODIES PROPRIETARY INFORMATION WHICH IS THE CONFIDENTIAL PROPERTY OF THE AVERY DENNISON CO. NONE OF WHICH SHALL BE COPIED, REPRODUCED, DISCLOSED TO OTHERS, PUBLISHED OR USED IN WHOLE OR IN PART, FOR ANY PURPOSE OTHER THAN THAT FOR WHICH IT IS BEING MADE AVAILABLE WITHOUT THE EXPRESS ADVANCE WRITTEN PERMISSION OF A DULY AUTHORIZED AGENT OF THE COMPANY. THIS DOCUMENT IS THE PROPERTY OF THE AVERY DENNISON CO. AND IS TO BE RETURNED TO THE COMPANY ON DEMAND.

REV.	DATE	DESCRIPTION
D	02.22.19	UPDATED TO NEW FORMAT; ADDED SPECIAL CHARACT.; ADDED -0 TO PN; TEETH LENGTH DIM MADE REF.

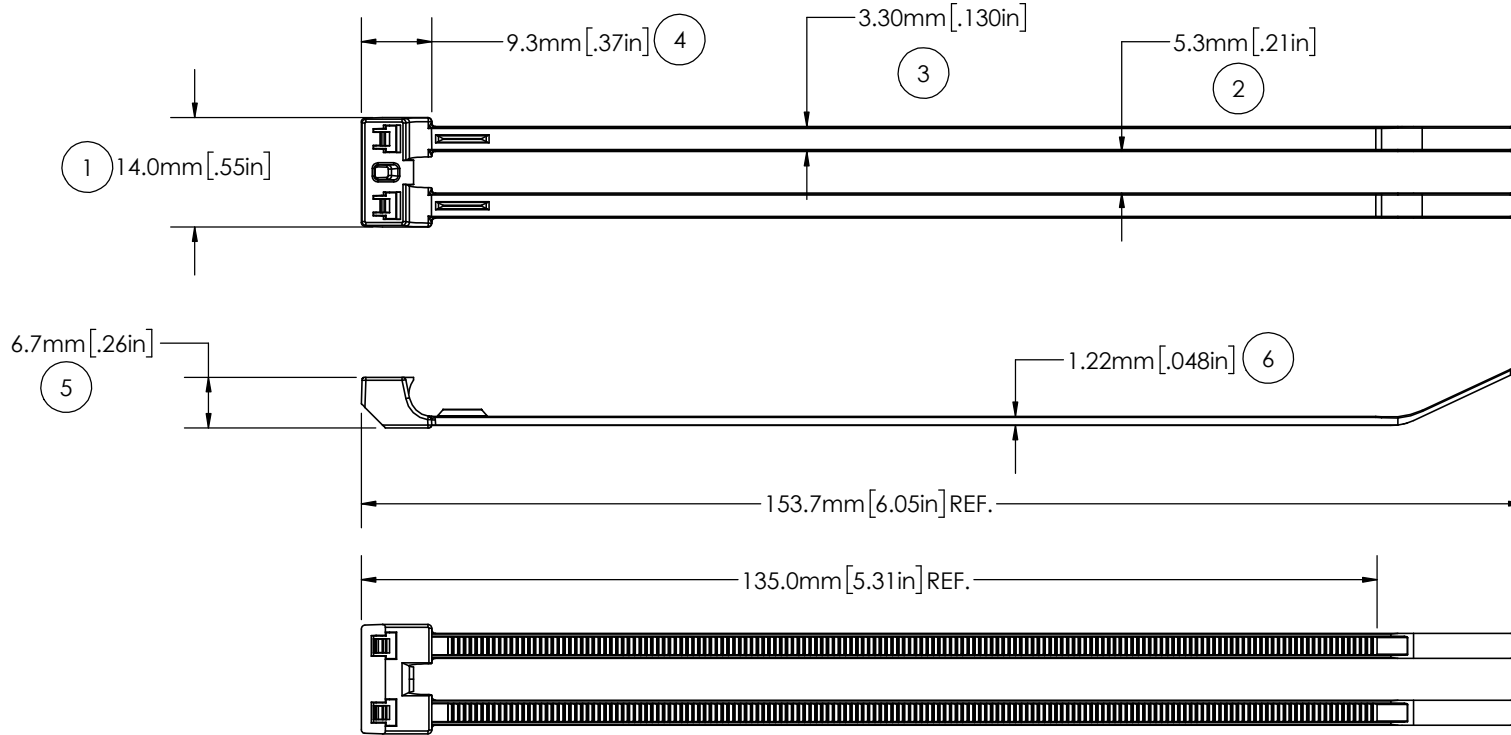

NOTES:

1. Δ = INDICATES SPECIAL CHARACTERISTIC

⑦	Δ FLAMMABILITY:	HB RATED PER FMVSS302	APPROVALS:	ENG. APPR. <i>Daniel Gilbertson</i>	02.22.19	 AVERY DENNISON <small>FASTENER DIVISION FITCHBURG, MA 01420 U.S.A. TEL. 1-800-225-5913 FAX. 978-353-8157</small>	DESCRIPTION	6" DOUBLE STRAP TIE
⑧	Δ TENSILE STRENGTH:	20 LBF /9.1 KGF MIN.		Q.A. APPR. <i>Caitlin Vaillancourt</i>	02.22.19			
	WEIGHT:	1.5g	SPECIFIED TOLERANCES ARE:	MATERIAL	NYLON 6/6, HEAT STABILIZED	COLOR	STOCK NO.	20040-0
	BUNDLE DIAMETER:	ϕ 6.0mm [.25in] TO ϕ 41.3mm [1.63in]		.XX \pm .03 IN. .X \pm .7 mm				
	TOOL:	12001 - HAND INSTALLATION TOOL 12500 - PNUM. INSTALLATION TOOL	.XXX \pm .01 IN. .XX \pm .25 mm	REV.	D			
	TOOL TENSION SETTING:	3 - 5	ANGULAR: \pm 2°					
	PACKAGING:	1000/BAG, 5000/CASE						

5

4

3

2

1